

Pyłoszczelna obrotowa zwrotnica rurowa 45° Staubdichter Drehrohrverteiler 45°

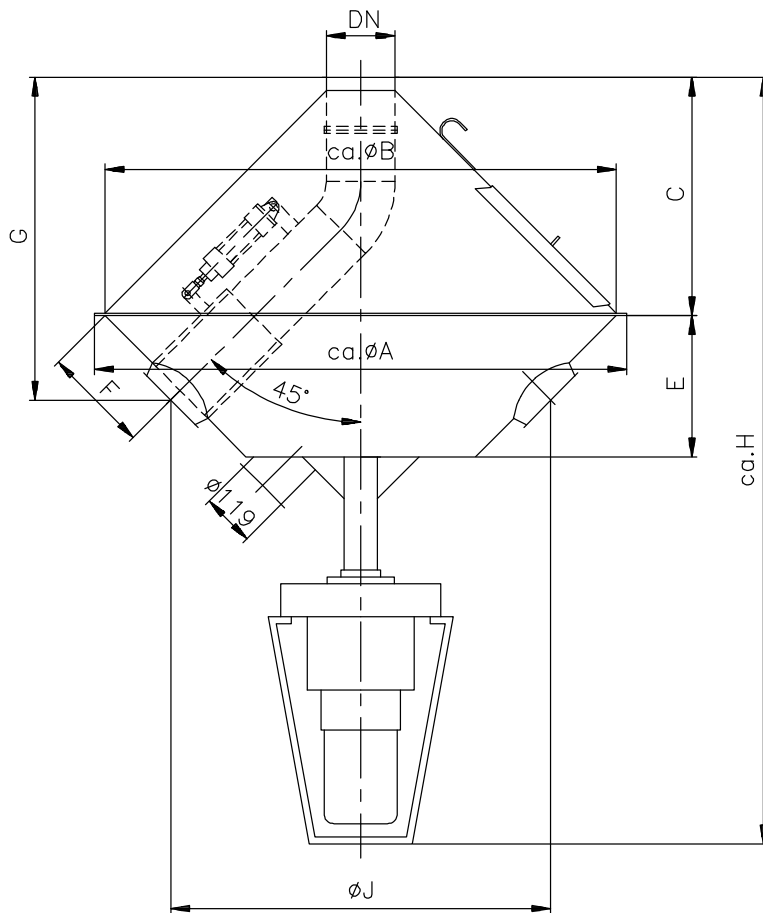

Dane wydajnościowe:

Dla produktów o ciężarze nasypowym 750 kg/m³ i stopniu wilgotności maks. 15% oraz nachyleniu rury obrotowej nie mniej jak 45°.

Leistungsdaten:

Für Produkte mit einem Schüttgewicht von 750 kg/m³ und einem Feuchtigkeitsgehalt von max. 15% und einer Drehrohrneigung nicht unter 45°.

Możliwości zastosowania :

Dla produktów pylistych w „wolnym spadzie“ o maksymalnym nadciśnieniu od 0,3 – 1,0 bar w zależności od średnicy nominalnej rury. Rozdzielacz może być instalowany tylko w pomieszczeniach zamkniętych. Uprasza się o zapytania w przypadku innego rodzaju stosowania. Przesławianie rozdzielaczy obrotowych nie może się odbywać w czasie trwania procesu zsypania produktu.

Dane techniczne:

Rura obrotowa jest zainstalowana w spawanym leju. Rozdzielacz jest kompletnie okablowany w skrzynce zaciskowej. Napięcie sterowania 24-220 V 50 Hz. Napięcie silnika 220/380 V 50 Hz. Inne napięcia na zamówienie. Dane dot. silników przekładniowych oraz siłowników patrz tabela danych

Einsatzmöglichkeiten:

Für staubige Produkte im „freien Fall“ mit einem max. Überdruck von 0,3 - 1,0 bar je nach Rohrnenweite. Der Verteiler darf nur in geschlossenen Räumen installiert werden. Bitte fragen Sie bei anderen Einsatzfällen an. Drehrohrverteiler dürfen nicht im Produktstrom geschaltet werden.

Technische Daten:

Das Drehrohr ist in einem geschweißten Trichter installiert. Der Verteiler ist komplett auf Klemmenkasten verdrahtet. Steuerspannung von 24-220 Volt/50Hz. Motorspannung 220/380 Volt/50Hz. Andere Spannungen sind auf Anfrage möglich. Daten bzgl. der Getriebe-motoren und der Zylindereinheiten siehe Datenblatt.

Podparcie 4 wspornikami na dolnym leju.

Abstützung durch 4 Konsolen am Untertrichter.

| DN | Wysyp Auslauf | Wydajność Leistung | A | B | C | E | F | G | H | J | Grubość ścianki rury obrotowej Wanddicke des Drehrohres | Ciężar w kg Gewicht in kg |
|-----|---------------|--------------------|------|------|-----|-----|-----|-----|------|-----|---|---------------------------|
| 100 | 4 | 8 t/h | 1220 | 1160 | 510 | 328 | 140 | 707 | 1498 | 940 | 3,6 | ca. 139 |
| | 6 | | | | | | | | | | | |
| | 8 | | | | | | | | | | | |
| | 10 | | | | | | | | | | | |
| | 12 | | | | | | | | | | | |
| | 14 | | | | | | | | | | | |
| | 16 | | | | | | | | | | | |
| 120 | 18 | 12 t/h | 1220 | 1160 | 480 | 328 | 155 | 716 | 1563 | 920 | 4,0 | ca. 146 |
| | 20 | | | | | | | | | | | |
| | 4 | | | | | | | | | | | |
| | 6 | | | | | | | | | | | |
| | 8 | | | | | | | | | | | |
| | 10 | | | | | | | | | | | |
| | 12 | | | | | | | | | | | |
| 150 | 14 | 25 t/h | 1220 | 1160 | 455 | 328 | 180 | 734 | 1418 | 850 | 4,5 | ca. 160 |
| | 16 | | | | | | | | | | | |
| | 18 | | | | | | | | | | | |
| | 20 | | | | | | | | | | | |
| | 4 | | | | | | | | | | | |
| | 6 | | | | | | | | | | | |
| | 8 | | | | | | | | | | | |
| 150 | 10 | 25 t/h | 1220 | 1160 | 455 | 328 | 180 | 734 | 1418 | 850 | 4,5 | ca. 160 |
| | 12 | | | | | | | | | | | |
| | 14 | | | | | | | | | | | |
| | 16 | | | | | | | | | | | |
| | 18 | | | | | | | | | | | |
| | 20 | | | | | | | | | | | |
| | 4 | | | | | | | | | | | |
| 150 | 6 | 25 t/h | 1220 | 1160 | 455 | 328 | 180 | 734 | 1418 | 850 | 4,5 | ca. 160 |
| | 8 | | | | | | | | | | | |
| | 10 | | | | | | | | | | | |
| | 12 | | | | | | | | | | | |
| | 14 | | | | | | | | | | | |
| | 16 | | | | | | | | | | | |
| | 18 | | | | | | | | | | | |
| 150 | 12 | 25 t/h | 1220 | 1160 | 455 | 328 | 180 | 734 | 1418 | 850 | 4,5 | ca. 160 |
| | 14 | | | | | | | | | | | |
| | 16 | | | | | | | | | | | |
| | 18 | | | | | | | | | | | |
| | 20 | | | | | | | | | | | |
| | 4 | | | | | | | | | | | |
| | 6 | | | | | | | | | | | |
| 150 | 8 | 25 t/h | 1220 | 1160 | 455 | 328 | 180 | 734 | 1418 | 850 | 4,5 | ca. 160 |
| | 10 | | | | | | | | | | | |
| | 12 | | | | | | | | | | | |
| | 14 | | | | | | | | | | | |
| | 16 | | | | | | | | | | | |
| | 18 | | | | | | | | | | | |
| | 20 | | | | | | | | | | | |
| 150 | 14 | 25 t/h | 1220 | 1160 | 455 | 328 | 180 | 734 | 1418 | 850 | 4,5 | ca. 160 |
| | 16 | | | | | | | | | | | |
| | 18 | | | | | | | | | | | |
| | 20 | | | | | | | | | | | |
| | 4 | | | | | | | | | | | |
| | 6 | | | | | | | | | | | |
| | 8 | | | | | | | | | | | |
| 150 | 10 | 25 t/h | 1220 | 1160 | 455 | 328 | 180 | 734 | 1418 | 850 | 4,5 | ca. 160 |
| | 12 | | | | | | | | | | | |
| | 14 | | | | | | | | | | | |
| | 16 | | | | | | | | | | | |
| | 18 | | | | | | | | | | | |
| | 20 | | | | | | | | | | | |
| | 4 | | | | | | | | | | | |
| 150 | 6 | 25 t/h | 1220 | 1160 | 455 | 328 | 180 | 734 | 1418 | 850 | 4,5 | ca. 160 |
| | 8 | | | | | | | | | | | |
| | 10 | | | | | | | | | | | |
| | 12 | | | | | | | | | | | |
| | 14 | | | | | | | | | | | |
| | 16 | | | | | | | | | | | |
| | 18 | | | | | | | | | | | |
| 150 | 12 | 25 t/h | 1220 | 1160 | 455 | 328 | 180 | 734 | 1418 | 850 | 4,5 | ca. 160 |
| | 14 | | | | | | | | | | | |
| | 16 | | | | | | | | | | | |
| | 18 | | | | | | | | | | | |
| | 20 | | | | | | | | | | | |
| | 4 | | | | | | | | | | | |
| | 6 | | | | | | | | | | | |
| 150 | 8 | 25 t/h | 1220 | 1160 | 455 | 328 | 180 | 734 | 1418 | 850 | 4,5 | ca. 160 |
| | 10 | | | | | | | | | | | |
| | 12 | | | | | | | | | | | |
| | 14 | | | | | | | | | | | |
| | 16 | | | | | | | | | | | |
| | 18 | | | | | | | | | | | |
| | 20 | | | | | | | | | | | |
| 150 | 14 | 25 t/h | 1220 | 1160 | 455 | 328 | 180 | 734 | 1418 | 850 | 4,5 | ca. 160 |
| | 16 | | | | | | | | | | | |
| | 18 | | | | | | | | | | | |
| | 20 | | | | | | | | | | | |
| | 4 | | | | | | | | | | | |
| | 6 | | | | | | | | | | | |
| | 8 | | | | | | | | | | | |
| 150 | 10 | 25 t/h | 1220 | 1160 | 455 | 328 | 180 | 734 | 1418 | 850 | 4,5 | ca. 160 |
| | 12 | | | | | | | | | | | |
| | 14 | | | | | | | | | | | |
| | 16 | | | | | | | | | | | |
| | 18 | | | | | | | | | | | |
| | 20 | | | | | | | | | | | |
| | 4 | | | | | | | | | | | |
| 150 | 6 | 25 t/h | 1220 | 1160 | 455 | 328 | 180 | 734 | 1418 | 850 | 4,5 | ca. 160 |
| | 8 | | | | | | | | | | | |
| | 10 | | | | | | | | | | | |
| | 12 | | | | | | | | | | | |
| | 14 | | | | | | | | | | | |
| | 16 | | | | | | | | | | | |
| | 18 | | | | | | | | | | | |
| 150 | 12 | 25 t/h | 1220 | 1160 | 455 | 328 | 180 | 734 | 1418 | 850 | 4,5 | ca. 160 |
| | 14 | | | | | | | | | | | |
| | 16 | | | | | | | | | | | |
| | 18 | | | | | | | | | | | |
| | 20 | | | | | | | | | | | |
| | 4 | | | | | | | | | | | |
| | 6 | | | | | | | | | | | |
| 150 | 8 | 25 t/h | 1220 | 1160 | 455 | 328 | 180 | 734 | 1418 | 850 | 4,5 | ca. 160 |
| | 10 | | | | | | | | | | | |
| | 12 | | | | | | | | | | | |
| | 14 | | | | | | | | | | | |
| | 16 | | | | | | | | | | | |
| | 18 | | | | | | | | | | | |
| | 20 | | | | | | | | | | | |
| 150 | 14 | 25 t/h | 1220 | 1160 | 455 | 328 | 180 | 734 | 1418 | 850 | 4,5 | ca. 160 |
| | 16 | | | | | | | | | | | |
| | 18 | | | | | | | | | | | |
| | 20 | | | | | | | | | | | |
| | 4 | | | | | | | | | | | |
| | 6 | | | | | | | | | | | |
| | 8 | | | | | | | | | | | |
| 150 | 10 | 25 t/h | 1220 | 1160 | 455 | 328 | 180 | 734 | 1418 | 850 | 4,5 | ca. 160 |
| | 12 | | | | | | | | | | | |
| | 14 | | | | | | | | | | | |
| | 16 | | | | | | | | | | | |
| | 18 | | | | | | | | | | | |
| | 20 | | | | | | | | | | | |
| | 4 | | | | | | | | | | | |
| 150 | 6 | 25 t/h | 1220 | 1160 | 455 | 328 | 180 | 734 | 1418 | 850 | 4,5 | ca. 160 |
| | 8 | | | | | | | | | | | |
| | 10 | | | | | | | | | | | |
| | 12 | | | | | | | | | | | |
| | 14 | | | | | | | | | | | |
| | 16 | | | | | | | | | | | |
| | 18 | | | | | | | | | | | |
| 150 | 12 | 25 t/h | 1220 | 1160 | 455 | 328 | 180 | 734 | 1418 | 850 | 4,5 | ca. 160 |
| | 14 | | | | | | | | | | | |
| | 16 | | | | | | | | | | | |
| | 18 | | | | | | | | | | | |
| | 20 | | | | | | | | | | | |
| | 4 | | | | | | | | | | | |
| | 6 | | | | | | | | | | | |
| 150 | 8 | 25 t/h | 1220 | 1160 | 455 | 328 | 180 | 734 | 1418 | 850 | 4,5 | ca. 160 |
| | 10 | | | | | | | | | | | |
| | 12 | | | | | | | | | | | |
| | 14 | | | | | | | | | | | |
| | 16 | | | | | | | | | | | |
| | 18 | | | | | | | | | | | |
| | 20 | | | | | | | | | | | |
| 150 | 14 | 25 t/h | 1220 | 1160 | 455 | 328 | 180 | 734 | 1418 | 850 | 4,5 | ca. 160 |
| | 16 | | | | | | | | | | | |
| | 18 | | | | | | | | | | | |
| | 20 | | | | | | | | | | | |
| | 4 | | | | | | | | | | | |
| | 6 | | | | | | | | | | | |
| | 8 | | | | | | | | | | | |
| 150 | 10 | 25 t/h | 1220 | 1160 | 455 | 328 | 180 | 734 | 1418 | 850 | 4,5 | ca. 160 |
| | 12 | | | | | | | | | | | |
| | 14 | | | | | | | | | | | |
| | 16 | | | | | | | | | | | |
| | 18 | | | | | | | | | | | |
| | 20 | | | | | | | | | | | |
| | 4 | | | | | | | | | | | |
| 150 | 6 | 25 t/h | 1220 | 1160 | 455 | 328 | 180 | 734 | 1418 | 850 | 4,5 | ca. 160 |
| | 8 | | | | | | | | | | | |
| | 10 | | | | | | | | | | | |
| | 12 | | | | | | | | | | | |
| | 14 | | | | | | | | | | | |
| | 16 | | | | | | | | | | | |
| | 18 | | | | | | | | | | | |
| 150 | 12 | 25 t/h | 1220 | 1160 | 455 | 328 | 180 | 734 | 1418 | 850 | 4,5 | ca. 160 |
| | 14 | | | | | | | | | | | |
| | 16 | | | | | | | | | | | |
| | 18 | | | | | | | | | | | |
| | 20 | | | | | | | | | | | |
| | 4 | | | | | | | | | | | |
| | 6 | | | | | | | | | | | |
| 150 | 8 | 25 t/h | 1220 | 1160 | 455 | 328 | 180 | 734 | 1418 | 850 | 4,5 | ca. 160 |
| | 10 | | | | | | | | | | | |
| | 12 | | | | | | | | | | | |
| | 14 | | | | | | | | | | | |
| | 16 | | | | | | | | | | | |
| | 18 | | | | | | | | | | | |
| | 20 | | | | | | | | | | | |
| 150 | 14 | 25 t/h | 1220 | 1160 | 455 | 328 | 180 | 734 | 1418 | 850 | 4,5 | ca. 160 |
| | 16 | | | | | | | | | | | |
| | 18 | | | | | | | | | | | |
| | 20 | | | | | | | | | | | |
| | 4 | | | | | | | | | | | |
| | 6 | | | | | | | | | | | |
| | 8 | | | | | | | | | | | |
| 150 | 10 | 25 t/h | 1220 | 1160 | 455 | 328 | 180 | 734 | 1418 | 850 | 4,5 | ca. 160 |
| | 12 | | | | | | | | | | | |
| | 14 | | | | | | | | | | | |
| | 16 | | | | | | | | | | | |
| | 18 | | | | | | | | | | | |
| | 20 | | | | | | | | | | | |
| | 4 | | | | | | | | | | | |
| 150 | 6 | 25 t/h | 1220 | 1160 | 455 | 328 | 180 | 734 | 1418 | 850 | 4,5 | ca. 160 |
| | 8 | | | | | | | | | | | |
| | 10 | | | | | | | | | | | |
| | 12 | | | | | | | | | | | |
| | 14 | | | | | | | | | | | |
| | 16 | | | | | | | | | | | |
| | 18 | | | | | | | | | | | |
| 150 | 12 | 25 t/h | 1220 | 1160 | 455 | 328 | 180 | 734 | 1418 | 850 | 4,5 | ca. 160 |
| | 14 | | | | | | | | | | | |
| | 16 | | | | | | | | | | | |
| | 18 | | | | | | | | | | | |
| | 20 | | | | | | | | | | | |
| | 4 | | | | | | | | | | | |
| | 6 | | | | | | | | | | | |
| 150 | 8 | 25 t/h | 1220 | 1160 | 455 | 328 | 180 | 734 | 1418 | 850 | 4,5 | ca. 160 |
| | 10 | | | | | | | | | | | |
| | 12 | | | | | | | | | | | |
| | 14 | | | | | | | | | | | |
| | 16 | | | | | | | | | | | |
| | 18 | | | | | | | | | | | |
| | 20 | | | | | | | | | | | |
| 150 | 14 | 25 t/h | 1220 | 1160 | 455 | 328 | 180 | 734 | 1418 | 850 | 4,5 | ca. 160 |
| | 16 | | | | | | | | | | | |
| | 18 | | | | | | | | | | | |
| | 20 | | | | | | | | | | | |
| | 4 | | | | | | | | | | | |
| | 6 | | | | | | | | | | | |
| | 8 | | | | | | | | | | | |
| 150 | 10 | 25 t/h | 1220 | 1160 | 455 | 328 | 180 | 734 | 1418 | 850 | 4,5 | ca. 160 |
| | 12 | | | | | | | | | | | |
| | 14 | | | | | | | | | | | |
| | 16 | | | | | | | | | | | |
| | 18 | | | | | | | | | | | |
| | 20 | | | | | | | | | | | |
| | 4 | | | | | | | | | | | |
| 150 | 6 | 25 t/h | 1220 | 1160 | 455 | 328 | 180 | 734 | 1418 | 850 | 4,5 | ca. 160 |
| | 8 | | | | | | | | | | | |
| | 10 | | | | | | | | | | | |
| | 12 | | | | | | | | | | | |
| | 14 | | | | | | | | | | | |
| | 16 | | | | | | | | | | | |
| | 18 | | | | | | | | | | | |
| 150 | 12 | 25 t/h | 1220 | 1160 | 455 | 328 | 180 | 734 | 1418 | 850 | 4,5 | ca. 160 |
| | 14 | | | | | | | | | | | |
| | 16 | | | | | | | | | | | |
| | 18 | | | | | | | | | | | |
| | 20 | | | | | | | | | | | |
| | 4 | | | | | | | | | | | |
| | 6 | | | | | | | | | | | |
| 150 | 8 | 25 t/h | 1220 | 1160 | 455 | 328 | 180 | 734 | 1418 | 850 | 4,5 | ca. 160 |
| | 10 | | | | | | | | | | | |
| | 12 | | | | | | | | | | | |
| | 14 | | | | | | | | | | | |
| | 16 | | | | | | | | | | | |
| | 18 | | | | | | | | | | | |
| | 20 | | | | | | | | | | | |
| 150 | 14 | 25 t/h | 1220 | 1160 | 455 | 328 | 180 | 734 | 1418 | 850 | 4,5 | ca. 160 |
| | 16 | | | | | | | | | | | |
| | 18 | | | | | | | | | | | |
| | 20 | | | | | | | | | | | |
| | 4 | | | | | | | | | | | |
| | 6 | | | | | | | | | | | |
| | 8 | | | | | | | | | | | |
| 150 | 10 | 25 t/h | 1220 | 1160 | 455 | 328 | 180 | 734 | 1418 | 850 | 4,5 | ca. 160 |
| | 12 | | | | | | | | | | | |
| | 14 | | | | | | | | | | | |
| | 16 | | | | | | | | | | | |
| | 18 | | | | | | | | | | | |
| | 20 | | | | | | | | | | | |
| | 4 | | | | | | | | | | | |
| 150 | 6 | 25 t/h | 1220 | 1160 | 455 | 328 | 180 | 734 | 1418 | 850 | 4,5 | ca. 160 |
| | 8 | | | | | | | | | | | |
| | 10 | | | | | | | | | | | |
| | 12 | | | | | | | | | | | |
| | 14 | | | | | | | | | | | |
| | 16 | | | | | | | | | | | |
| | 18 | | | | | | | | | | | |
| 150 | 12 | 25 t/h | 1220 | 1160 | 455 | 328 | 180 | 734 | 1418 | 850 | 4,5 | ca. 160 |
| | 14 | | | | | | | | | | | |
| | 16 | | | | | | | | | | | |
| | 18 | | | | | | | | | | | |
| | 20 | | | | | | | | | | | |
| | 4 | | | | | | | | | | | |
| | 6 | | | | | | | | | | | |
| 150 | 8 | 25 t/h | 1220 | 1160 | 455 | 328 | 180 | 734 | 1418 | 850 | 4,5 | ca. 160 |
| | 10 | | | | | | | | | | | |
| | 12 | | | | | | | | | | | |
| | 14 | | | | | | | | | | | |
| | 16 | | | | | | | | | | | |
| | 18 | | | | | | | | | | | |
| | 20 | | | | | | | | | | | |
| 150 | 14 | 25 t/h | 1220 | 1160 | 455 | 328 | 180 | 734 | 1418 | 850 | 4,5 | ca. 160 |
| | 16 | | | | | | | | | | | |
| | 18 | | | | | | | | | | | |
| | 20 | | | | | | | | | | | |
| | 4 | | | | | | | | | | | |
| | 6 | | | | | | | | | | | |
| | 8 | | | | | | | | | | | |
| 150 | 10 | 25 t/h | 1220 | 1160 | 455 | 328 | 180 | 734 | 1418 | 850 | 4,5 | ca. 160 |
| | 12 | | | | | | | | | | | |
| | 14 | | | | | | | | | | | |
| | 16 | | | | | | | | | | | |
| | 18 | | | | | | | | | | | |
| | 20 | | | | | | | | | | | |
| | 4 | | | | | | | | | | | |
| 150 | 6 | 25 t/h | 1220 | 1160 | 455 | 328 | 180 | 734 | 1418 | 850 | 4,5 | ca. 160 |
| | 8 | | | | | | | | | | | |
| | 10 | | | | | | | | | | | |
| | 12 | | | | | | | | | | | |
| | 14 | | | | | | | | | | | |
| | 16 | | | | | | | | | | | |
| | 18 | | | | | | | | | | | |
| 150 | 12 | 25 t/h | 1220 | 1160 | 455 | 328 | 180 | 734 | 1418 | 850 | 4,5 | ca. 160 |
| | 14 | | | | | | | | | | | |
| | 16 | | | | | | | | | | | |
| | 18 | | | | | | | | | | | |
| | 20 | | | | | | | | | | | |
| | 4 | | | | | | | | | | | |
| | 6 | | | | | | | | | | | |
| 150 | 8 | 25 t/h | 1220 | 1160 | | | | | | | | |